

Analog Input Module

IC670ALG620

GFK-1206D
June 1997

RTD Input Module

The RTD Analog Input Module (IC670ALG620) accepts inputs from 4 independent 3-wire and/or 4-wire platinum, nickel, nickel/iron, or copper RTDs.

Module features include:

- Selectable resistance measurements in tenths of ohms, tenths of degrees Fahrenheit, or tenths of degrees Celsius
- Individual channel configuration
- Selectable resistance ranges: 0 – 500 ohms and 0 – 3000 ohms
- Selectable RTD input as resistance or temperature (Celsius or Fahrenheit)
- Report high/low, underrange/overrange, open wire and input short alarms.
- Uses optional discrete inputs and outputs for status and control.
- Two data acquisition rates based on 50 Hz and 60 Hz line frequencies
- Configurable channel activation

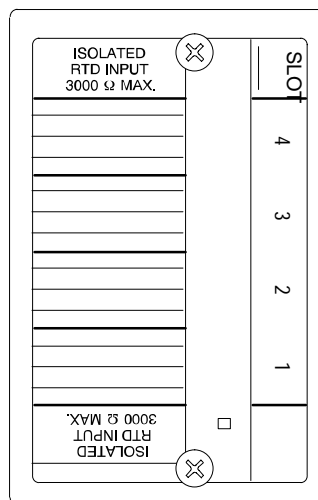

46722

Power Sources

No loop power is required for this module. The excitation current for the RTDs is provided by the module, which automatically matches the excitation current to each configured RTD type.

LED

A single indicator shows module status:

- ON: normal operation
- Intermittent flashing: module fault
- OFF: loss of backplane power or fatal fault

Module Operation

The RTD Input Module accepts four inputs from three-wire or four-wire RTDs and converts the input level to a digital value. Input spans support a variety of RTD types, as listed in the Module Specifications section.

The analog/digital converter reads the voltage generated by each of the four inputs. The A/D converter converts the differential measurement into a binary value (15 bits plus sign), which is read by the block's microprocessor. The microprocessor sets the gain required in the analog/digital converter for each individual input. The gain is based on the RTD type that has been configured for that input.

The microprocessor selects the input by means of a solid state, optically-coupled multiplexer. Three measurements are made for each input: Excitation current, RTD resistance including field wire drop, and field wire drop. From these three measurements, the module calculates the RTD resistance. A DC/DC converter circuit isolates the field side from the logic circuits.

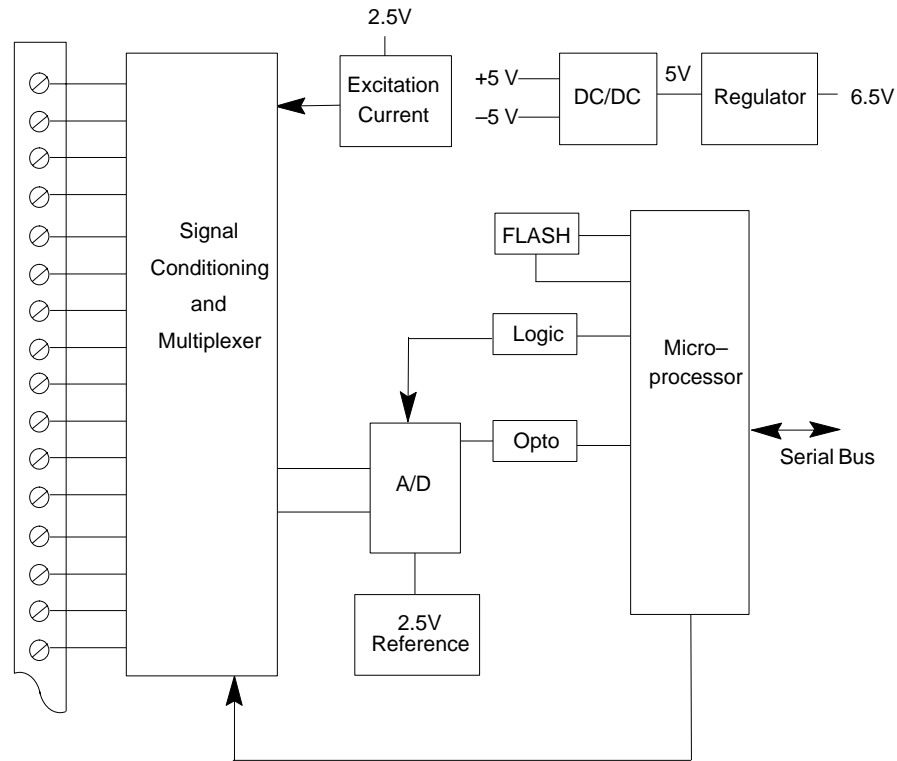

46723

Calibration

The module automatically performs A/D calibration at powerup. Automatic calibration is then repeated every minute to compensate for changes in the ambient temperature.

The module stores the calibration constants for each gain in RAM memory. This data can be read and changed if necessary.

RTD Input Module

GFK-1206D

June 1997

Host Interface

The RTD Input module has the following data types:

- 4 analog inputs (4 words)
- 32 bits of discrete input data for module and channel status (use of this data is optional)
- 8 bits of discrete output data for fault clearing to the module (also optional)
- Analog output data defaults to a length of 0, and should NOT be used for most applications.

A starting reference and length in the Bus Interface Unit (BIU) data tables for each data type is selected during module configuration. Depending on the configuration that has been set up for each RTD, the input data can be reported as tenths of ohms, tenths of degrees Fahrenheit, or tenths of degrees Celsius.

This module exchanges data with a BIU in the same manner as other types of I/O modules—it provides all its input data and status bits when requested by the BIU, and receives fault-clearing commands from the BIU via its assigned output bits. Note that the BIU can be configured not to send status data over the network.

The module can also be configured for “Group” data transfer with the BIU or with other intelligent devices in the same Field Control station. Group data transfer, and the steps for configuring it, are described in the *Bus Interface Unit User’s Manual*.

UnitsSelected	IntegerRanges	EngineeringUnits Ranges
Tenths of Degrees	-32767 to +32767	-3276.7 to +3276.7
Tenths of Ohms	0 to 65535	0 Ohms to 6553.5 Ohms

Compatibility

This module must be used with a Bus Interface Unit revision 2.0 or later.

Module Configuration Overview

Like other Field Control modules, the RTD Input module is usually configured from the Bus Interface Unit, using a compatible hand-held programmer. The module will also accept configuration data from the bus when used in a system that supports such configuration. The table below summarizes configuration choices and defaults. The module will power up with the default configuration settings. For configuration instructions, refer to the *Bus Interface Unit User's Manual*.

Module Parameter	Description	Default	Choices
AnalogInput Data Length	Word length of the module's analog input data in the BIU's analog input (AI) data table.	4	0-4
AnalogInput Data Reference	Starting offset for the module's analog input data in the BIU's analog input (AI) table.		userselectable
Discrete Input Data Length	Bit length for the module's optional status data in the BIU's discrete input (I) table.	32	0-32
Discrete Input Data Reference	Starting offset for the module's status data in the BIU's discrete input (I) table.		userselectable
Discrete Output Data Length	Bit length for the module's optional fault-clearing bits in the BIU's discrete output (Q) table.	8	0-8
Discrete Output Data Reference	Starting offset for the module's optional fault-clearing bits in the BIU's discrete output table.		userselectable
AnalogOutput Data Length	Word length for analog output data in the BIU's analog output (AQ) table. Should not be used for most applications.	0	0-4
AnalogOutput Data Reference	Starting offset for the module's analog output data in the BIU's AQ table.		userselectable
Line Frequency	Specifies the line frequency.	60 Hz	50 Hz, 60 Hz
Channel Active	Specifies if the channel should return data and alarms. If a channel is "inactive" space is still allocated for it.	Active	Inactive (off), Active (on)
Units	The conversion type for each RTD.	Deg C	tenths of ohms, tenths of degrees C, or tenths of degrees F
RTD Type	The type of RTD used for each channel.	100 PT 385	10 PT, 25 PT, 25.5 PT 392, 100 PT 385, 100 PT 3902, 100 PT 392, 100 PT 3923, 100 PT 3916, 1K PT 375, 10 CU, 10 CU 427, 50 CU 427, 100 CU 427, 100 NI, 100 NI 618, 120 NI 672 604 NI/FE518, 1KNI/FE527, 500 Ohm, 3000 Ohm
Wire Type	The type of field wiring for each RTD.	3 Wire	3 Wire, 4 Wire
Alarm Low	The low alarm limit for the channel, in engineering units.	-200	-32,768 to +32,767
Alarm High	The high alarm limit for the channel, in engineering units.	800	-32,768 to +32,767
Resistance	An optional resistance adjustment, in tenths of ohms.	0	0 to 3276.7

RTD Input Module

GFK-1206D

June 1997

Module Features

Channel Active

Each channel can be configured as either active or inactive.

If a channel is inactive, it is not scanned and a value of 0 is returned to the BIU.

If a channel is active, and the configured analog input data length is not long enough to accommodate the data for a particular channel, the data for that channel is still processed, since the response to a group command may be used to transmit that channel's data to the BIU.

Low Alarm Limit and High Alarm Limit

Each input channel can have a low alarm limit and a high alarm limit. If an input reaches one of its limits, the module reports the actual value and sends the appropriate diagnostic bit in the discrete input table of the BIU. Alarms do not stop the process or change the value of the input.

Alarm limits can be set anywhere over the dynamic range of the signal. The range for each is - 32,768 to +32,767. The high alarm limit must be greater than the low alarm limit. If alarm reporting is not wanted, alarm limits can be set beyond the dynamic range of the signal so they will never be activated.

Input Selection to Include RTD Type

Each input channel can have a different RTD type, selectable from a list of many different RTDs.

If the actual RTD resistance does not match the defined type, an adjustment factor can be configured in tenths of ohms.

Selection	Comments	Selection	Comments	Selection	Comments
10 PT	10 Ohm Platinum (PT)	100 PT 3916	100 Ohm Platinum, $\alpha=.003916$	100 NI 618	100 Ohm Nickel At 0C, DIN43760, $\alpha=.00618$
25 PT	25 Ohm Platinum IPTS-68	1K PT 375	1 KOhm Platinum, $\alpha=.00375$	120 NI 672	120 Ohm Nickel, at 0C, $\alpha=.00672$
25.5 PT 392	25.5 Ohm Platinum, $\alpha=.00392$ at 0C Lab Std	10 CU	10 Ohm Copper, at 25C, IPTS-68	604NI/FE518	604 Ohm Nickel/Iron at 0C, $\alpha=.00518$
100 PT 385	100 Ohm Platinum, DIN43760, $\alpha=.00385$	9.035 CU 427	9.035 Ohm Copper, at 25C, $\alpha=.00427$	IKNI/FE527	1 KOhm Nickel/Iron, at 70F, $\alpha=.00527$
100 PT 3902	100 Ohm Platinum, $\alpha=.003902$	50 CU 427	50 Ohm Copper, $\alpha=.00427$	500 OHM	Select UNITS of 1/10 Ohms
100 PT 392	100 Ohm Platinum, $\alpha=.00392$ IPTS-6 8	100 CU 427	100 Ohm Copper, $\alpha=.00427$	3000 OHM	Select UNITS of 1/10 Ohms
100 PT 3923	98.13 Ohm Platinum, $\alpha=.003923$	100 NI	100 Ohm Nickel, IPTS-68		

RTD Limits

The table below lists the ohms and temperature limits for different RTD types.

RTD Type	Low Ω Limit	High Ω Limit	Low Temp. C	High Temp. C
10 Ohm Copper @ 25C	6.13600	14.8200	-75.00	150.00
10 Ohm Platinum @ 25C	7.02000	37.2599	-70.00	1000.00
25 Ohm Platinum	4.14500	74.3089	-201.1111	537.77
100 Ohm Nickel	80.88890	147.7700	-40.00	140.00
1 KOhm Platinum, $\alpha=.00375$	199.4880	2754.620	-200.00	500.00
100 Ohm Platinum $\alpha=.00385$	27.01	389.936	-180.0	850.0
100 Ohm Platinum, $\alpha=.003902$	93.5400	135.000	-17.7777	99.9999
100 Ohm Platinum IPTS68 (PA)	26.5	327.744	-200.0	630.0
100 Ohm Platinum SAMA-RC21-4 (PC)	26.5	311.874	-200.0	600.0
100 Ohm Platinum JISC-1604-'81	26.5	323.780	-200.0	620.0
25.5 Ohm Platinum Lab Std (PJ)	4.50	83.575	-200.0	630.0
9.035 Ohm Copper (CA)	6.05	16.400	-100.0	260.0
50 Ohm Copper (CB/2)	28.379	105.787	-100.0	260.0
100 Ohm Copper (CB)	56.757	211.574	-100.0	260.0
100 Ohm Nickel (NB)	69.520	223.221	-60.0	180.0
120 Ohm Nickel (NA)	66.600	380.310	-80.0	260.0
604 Ohm Nickel/Iron(FA)	372.789	1318.722	-100.0	204.0
1 KOhm Nickel/Iron(FB)	566.576	1985.891	-100.0	204.0

RTD Input ModuleGFK-1206D
June 1997**Module Specifications**

Module Characteristics	
Number of Channels	Four 3-wire and/or 4-wire RTDs
Scan time	60 Hz: approximately 210 milliseconds per point 50 Hz: approximately 230 milliseconds per point,
Fault detection	Open RTD, input short, underrange, overrange, and high/low alarm
Normal mode rejection	60dB, at 50/60 Hz, 100% span
Common mode rejection	120 dB at 50/60 Hz, 100 ohm imbalance
Common mode voltage	250 Vrms (350 VDC or peak AC)
Normal mode voltage	100% overrange DC or peak AC operational 28 VDC or peak AC maximum
Isolation: User input to logic, user input to frame ground. Channel to Channel	1500 VAC for 1 minute, 250 VAC continuous. 250 VAC continuous.
Current drawn from BIU power supply	190 mA maximum
Digital Resolution	15 bits plus sign
Operating temperature range	0 to 55 Degrees C ambient
Channel Characteristics	
RTD types	10, 25, 100, and 1000 ohm platinum 10 and 100 ohm copper 100, 50, and 120 ohm nickel 604 ohms and 1000 ohms nickel/iron
Resistance ranges	0 to 500 ohms 0 to 3000 ohms
Accuracy, at 25 C	RTD: +/-0.15% of reading, +/-0.3 to 0.5 degree Celsius, depending on type
Temperature sensitivity (0 to 60C)	+/-0.004% of reading, +/-1.5µV per C referred to input
Maximum lead resistance	5 ohms per lead

Keying Locations

Optional keying locations for the RTD Module are:

Keying Locations									
A	B	C	D	E	F	G	H	J	K
✓			✓				✓	✓	

Field Wiring

The following illustration shows connections for 3-wire and 4-wire RTDs.

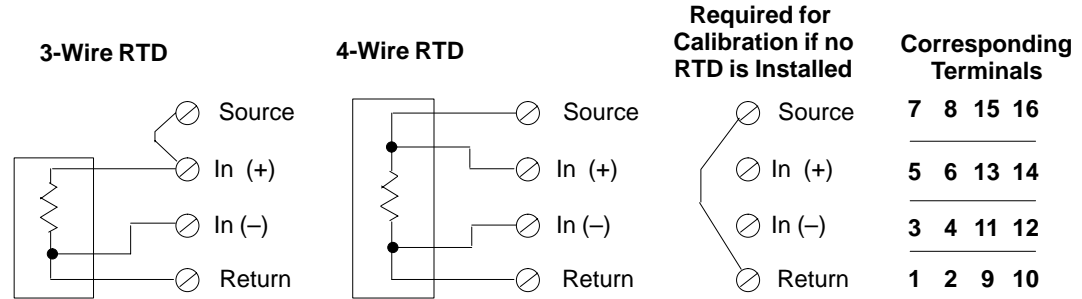

46724

No loop power is required for this module. The excitation current for the RTDs is provided by the module, which automatically matches the excitation current to each configured RTD type.

I/O Terminal Block Terminal Assignments

The Terminal Block with box terminals (IC670CHS002) has 25 terminals for each module. Each accommodates one AWG #14 (avg 2.1mm² cross section) to AWG #22 (avg 0.36mm² cross section) wire, or two wires up to AWG #18 (avg. 0.86mm² cross section). When an external jumper is used, wire capacity is reduced from AWG #14 (2.10mm²) to AWG #16 (1.32mm²).

The I/O Terminal Block with barrier terminals (IC670CHS001) has 18 terminals per module. Each terminal can accommodate one or two wires up to AWG #14 (avg 2.1mm² cross section).

The I/O Terminal Block with Connectors (IC670CHS003) has one 20-pin male connector per module.

I/O Terminal Block with Box Terminals (IC670CHS002 and 102)	I/O Terminal Block with Barrier Terminals (IC670CHS001 and 101)	I/O Terminal Block with Wire to Board Connectors (IC670CHS003 and 103)																																																																																																																																												
<table border="0"> <tr><td>Source 4</td><td>16</td><td></td><td>Source 3</td></tr> <tr><td>In (+) 4</td><td>14</td><td>15</td><td>In (+) 3</td></tr> <tr><td>not used</td><td>E8</td><td>13</td><td></td></tr> <tr><td>In (-) 4</td><td>12</td><td></td><td>In (-) 3</td></tr> <tr><td>Return 4</td><td>10</td><td>11</td><td>Return 3</td></tr> <tr><td>not used</td><td>E6</td><td>9</td><td></td></tr> <tr><td>Source 2</td><td>8</td><td></td><td>Source 1</td></tr> <tr><td>In (+) 2</td><td>6</td><td>7</td><td>In (+) 1</td></tr> <tr><td>not used</td><td>E4</td><td>5</td><td></td></tr> <tr><td>In (-) 2</td><td>4</td><td></td><td>In (-) 1</td></tr> <tr><td>Return 2</td><td>2</td><td>3</td><td>Return 1</td></tr> <tr><td>not used</td><td>E2</td><td>1</td><td>not used</td></tr> <tr><td>not used</td><td>B2</td><td></td><td>not used</td></tr> <tr><td>not used</td><td>B1</td><td>E1</td><td>not used</td></tr> <tr><td></td><td></td><td>A2</td><td>not used</td></tr> <tr><td></td><td></td><td>A1</td><td>not used</td></tr> </table> <p>Terminals E1, E2, E4, E6, and E8 are electrically connected together, A1 and A2 are electrically connected together, B1 and B2 are electrically connected together.</p>	Source 4	16		Source 3	In (+) 4	14	15	In (+) 3	not used	E8	13		In (-) 4	12		In (-) 3	Return 4	10	11	Return 3	not used	E6	9		Source 2	8		Source 1	In (+) 2	6	7	In (+) 1	not used	E4	5		In (-) 2	4		In (-) 1	Return 2	2	3	Return 1	not used	E2	1	not used	not used	B2		not used	not used	B1	E1	not used			A2	not used			A1	not used	<table border="0"> <tr><td>Source 4</td><td>16</td><td>15</td><td>Source 3</td></tr> <tr><td>In (+) 4</td><td>14</td><td>13</td><td>In (+) 3</td></tr> <tr><td>In (-) 4</td><td>12</td><td>11</td><td>In (-) 3</td></tr> <tr><td>Return 4</td><td>10</td><td>9</td><td>Return 3</td></tr> <tr><td>Source 2</td><td>8</td><td>7</td><td>Source 1</td></tr> <tr><td>In (+) 2</td><td>6</td><td>5</td><td>In (+) 1</td></tr> <tr><td>In (-) 2</td><td>4</td><td>3</td><td>In (-) 1</td></tr> <tr><td>Return 2</td><td>2</td><td>1</td><td>Return 1</td></tr> <tr><td>not used</td><td>B</td><td>A</td><td>not used</td></tr> </table>	Source 4	16	15	Source 3	In (+) 4	14	13	In (+) 3	In (-) 4	12	11	In (-) 3	Return 4	10	9	Return 3	Source 2	8	7	Source 1	In (+) 2	6	5	In (+) 1	In (-) 2	4	3	In (-) 1	Return 2	2	1	Return 1	not used	B	A	not used	<table border="0"> <tr><td>In (-) 3</td><td>11</td><td>10</td><td>Return 4</td></tr> <tr><td>In (-) 4</td><td>12</td><td>9</td><td>Return 3</td></tr> <tr><td>In (+) 3</td><td>13</td><td>8</td><td>Source 2</td></tr> <tr><td>In (+) 4</td><td>14</td><td>7</td><td>Source 1</td></tr> <tr><td>Source 3</td><td>15</td><td>6</td><td>In (+) 2</td></tr> <tr><td>Source 4</td><td>16</td><td>5</td><td>In (+) 1</td></tr> <tr><td>not used</td><td>A2</td><td>4</td><td>In (-) 2</td></tr> <tr><td>not used</td><td>A1</td><td>3</td><td>In (-) 1</td></tr> <tr><td>not used</td><td>B2</td><td>2</td><td>Return 2</td></tr> <tr><td>not used</td><td>B1</td><td>1</td><td>Return 1</td></tr> </table>	In (-) 3	11	10	Return 4	In (-) 4	12	9	Return 3	In (+) 3	13	8	Source 2	In (+) 4	14	7	Source 1	Source 3	15	6	In (+) 2	Source 4	16	5	In (+) 1	not used	A2	4	In (-) 2	not used	A1	3	In (-) 1	not used	B2	2	Return 2	not used	B1	1	Return 1
Source 4	16		Source 3																																																																																																																																											
In (+) 4	14	15	In (+) 3																																																																																																																																											
not used	E8	13																																																																																																																																												
In (-) 4	12		In (-) 3																																																																																																																																											
Return 4	10	11	Return 3																																																																																																																																											
not used	E6	9																																																																																																																																												
Source 2	8		Source 1																																																																																																																																											
In (+) 2	6	7	In (+) 1																																																																																																																																											
not used	E4	5																																																																																																																																												
In (-) 2	4		In (-) 1																																																																																																																																											
Return 2	2	3	Return 1																																																																																																																																											
not used	E2	1	not used																																																																																																																																											
not used	B2		not used																																																																																																																																											
not used	B1	E1	not used																																																																																																																																											
		A2	not used																																																																																																																																											
		A1	not used																																																																																																																																											
Source 4	16	15	Source 3																																																																																																																																											
In (+) 4	14	13	In (+) 3																																																																																																																																											
In (-) 4	12	11	In (-) 3																																																																																																																																											
Return 4	10	9	Return 3																																																																																																																																											
Source 2	8	7	Source 1																																																																																																																																											
In (+) 2	6	5	In (+) 1																																																																																																																																											
In (-) 2	4	3	In (-) 1																																																																																																																																											
Return 2	2	1	Return 1																																																																																																																																											
not used	B	A	not used																																																																																																																																											
In (-) 3	11	10	Return 4																																																																																																																																											
In (-) 4	12	9	Return 3																																																																																																																																											
In (+) 3	13	8	Source 2																																																																																																																																											
In (+) 4	14	7	Source 1																																																																																																																																											
Source 3	15	6	In (+) 2																																																																																																																																											
Source 4	16	5	In (+) 1																																																																																																																																											
not used	A2	4	In (-) 2																																																																																																																																											
not used	A1	3	In (-) 1																																																																																																																																											
not used	B2	2	Return 2																																																																																																																																											
not used	B1	1	Return 1																																																																																																																																											

46725

RTD Input Module

GFK-1206D
June 1997

Diagnostics

The RTD module performs diagnostics and provides the diagnostic data to the BIU using its configured discrete input (I) references, starting at the configured reference offset.

The RTD sets the appropriate bit when a diagnostic condition is detected. The bit remains set until cleared.

Circuit Diagnostics Bits (byte 0)

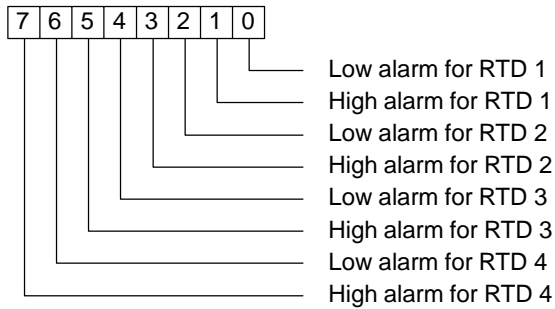

Circuit Diagnostics Bits (byte 2)

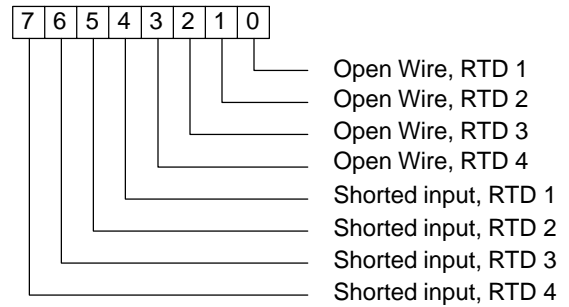

Circuit Diagnostics Bits (byte 1)

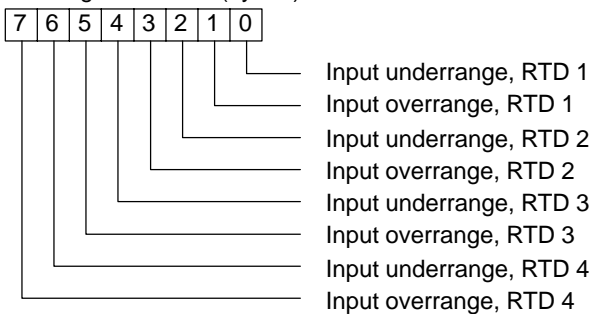

Circuit Diagnostics Bits (byte 3)

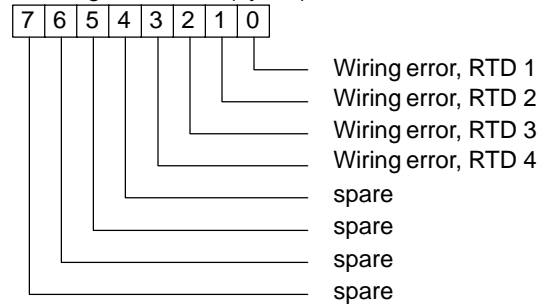

Clearing Faults and Alarms

Four optional discrete output bits in the BIU's discrete output (Q) table can be used to clear module faults and alarms.

Setting the discrete output bit for an RTD clears all diagnostic bits for that RTD that may be set.

Output Command Bits to Clear Diagnostics

